

Magnetic Sensor ICs

Omnipolar Detection High Performance Hall-Effect Sensor ICs



AS1153

● General Description

Using BCD process, the AS1153 is designed for high performance Omnipolar detection hall-effect application, such as automotive, industrial, electric tools, home appliances, rotor position sensing, brushless DC motor etc. The hall IC integrated an on-chip hall voltage generator for magnetic sensing, a comparator that amplifiers the hall voltage, hall sensor with dynamic offset cancellation system, an pull-up resistance, and a Schmitt trigger to provide switching hysteresis for noise rejection, and a voltage regulator for operation with supply voltage of 2.7V to 40V.

AS1153 is designed to respond to alternating North and South poles. When the magnetic flux density (B) is larger than operate point (B_{OP}), the output will be turned on (High), the output is held until the magnetic flux density (B) is lower than release point (B_{RP}), then turn off (low).

The device is available in SOT23-3L Package and is rated over the -40°C to 125°C . The all packages are RoHS and Green compliant.

● Features

- X and Z-axis Magnetic Flux Omnipolar Switch
- Omnipolar Operation, easy to use as output
- Input Voltage Range : 2.7V to 40V
- Very high sensitivity hall sensor
- Chopper stabilization amplifier stage
- High Magnetic Sensitivity
 - ✓ X-axis: $B_{OP} = \pm 60\text{Gauss}$, $B_{RP} = \pm 40\text{Gauss}$
 - ✓ Z-axis: $B_{OP} = \pm 30\text{Gauss}$, $B_{RP} = \pm 20\text{Gauss}$
- Good RF noise immunity
- PNP Open-Collector Output
- Small Solution Size
- RoHS & Green Compliant
- SOT23-3L Package
- -40°C to $+125^{\circ}\text{C}$ Temperature Range

● Applications

- Smart Meter
- Replace the Reed Switch
- Contact-less switch
- Air Cylinder, Antitheft window, Digital door lock
- Water Purifier, Humidifier Bidet
- Water Meter, Gas Meter, Wattmeter etc
- Washing Machine, Rice Cooker, Refrigerator, Electronic Dictionary, Digital Camera etc

■ Ordering Information

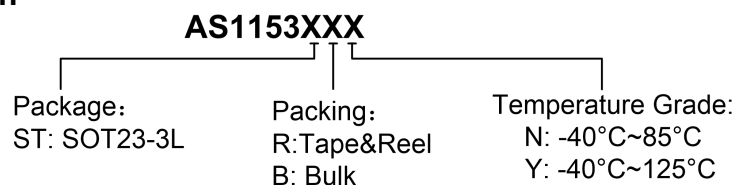

Part Number		B_{OP} (Gauss)	B_{RP} (Gauss)	Package Type	Package Qty	Temperature	Eco Plan
AS1153STRN	X	± 60	± 40	SOT23-3L	7-in reel 3000pcs/reel	$-40 \sim 85^{\circ}\text{C}$	Green
	Z	± 30	± 20				
AS1153STRY	X	± 60	± 40	SOT23-3L	7-in reel 3000pcs/reel	$-40 \sim 125^{\circ}\text{C}$	Green
	Z	± 30	± 20				

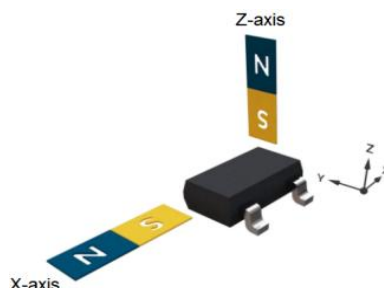
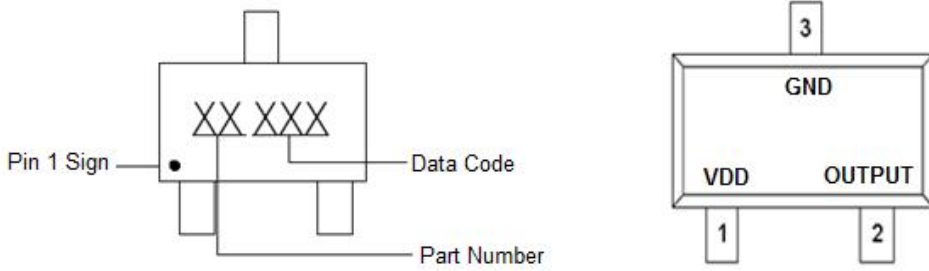

Fig 1, 3D (X/Z-Axis) Magnetic Operation of AS1153

■ **Marking & Pin Assignment**

SOT23-3L:



Pin Name	Pin No.	I/O	Pin Function
	SOT23-3L		
VDD	1	P	Input Power Supply
GND	3	P	Ground
OUTPUT	2	O	Output Pin

■ **Typical Application Circuit**

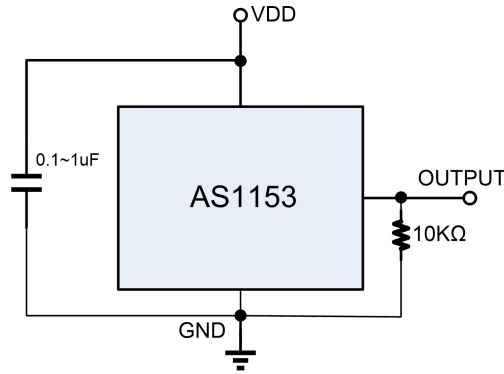

Figure 2, Typical Application Circuit of AS1153

■ **Block Diagram**

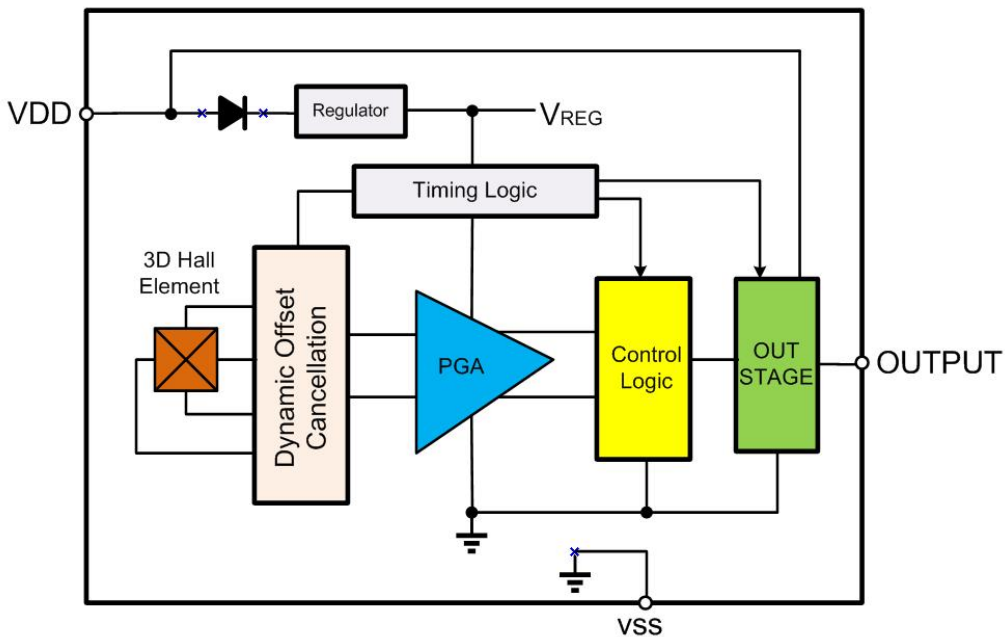

Figure 3, Block Diagram of AS1153

■ Absolute Maximum Ratings¹ ($T_A=25^{\circ}\text{C}$, unless otherwise noted)

Parameter	Symbol	Rating	Unit
V_{DD} Pin to GND	V_{DD}	-0.3 to 45	V
Output Pin to GND	V_{OUTPUT}	-0.3 to $V_{DD} + 0.3$	V
Max. Continuous Output Current	I_{OUTMAX}	30	mA
Package Power Dissipation	P_D	180	mW
ESD (HBM)	ESD	2000	V
Operating Junction Temperature Range	T_{OP}	-40 to +150	$^{\circ}\text{C}$
Maximum Soldering Temperature (at leads, 10 sec)	T_{LEAD}	260	$^{\circ}\text{C}$

■ Recommended Operating Conditions²

Parameter	Symbol	Rating	Unit
V_{DD} Pin to GND	V_{DD}	2.7 to 40	V
Continuous Output Current	I_{OUT}	30	mA
Operating Temperature Range	T_{OP}	-40 to +125	$^{\circ}\text{C}$

Note: 1: Stresses above those listed in absolute maximum ratings may cause permanent damage to the device. Functional operation at conditions other than the operating conditions specified is not implied. Only one absolute maximum rating should be applied at any one time. 2: The device is not guaranteed to function outside of its operating conditions.

■ Electrical Characteristics

($T_A = -40$ to $+85^{\circ}\text{C}$ unless otherwise noted. Typical values are at $T_A = +25^{\circ}\text{C}$, $V_{DD} = 12\text{V}$) (1mT=10Gauss)

Symbol	Parameter	Conditions	Min.	Typ.	Max.	Unit
V_{DD}	Input Voltage		2.7	12	40	V
I_{DD}	Supply Current	No Magnetic	-	4.0	-	mA
t_{ON}	Power On Time		-	35	50	μs
I_{OFF}	Off-state Leakage Current	Output Hi-Z	-	-	1.0	μA
V_{CESAT1}	Collector-Emitter Saturation Voltage	$I_C = -10\text{mA}$	-	-	-0.3	V
V_{CESAT2}		$I_C = -50\text{mA}$	-	-	-0.4	V
T_R	Output Rise Time	$R_L = 1\text{K}$, $C_L = 50\text{pF}$	-	-	0.5	μs
T_F	Output Fall Time	$R_L = 1\text{K}$, $C_L = 50\text{pF}$	-	-	0.2	μs
T_D	Output Delay Time	$B = B_{RP} - 100\text{Gs}$ to $B_{OP} + 100\text{Gs}$	-	15	25	μs
Magnetic Para. (X-Axis)						
B_{OPS}	Magnetic Operating Point		40	60	80	Gauss
B_{OPN}			-80	-60	-40	
B_{RPS}	Magnetic Release Point		10	40	70	Gauss
B_{RPN}			-70	-40	-10	
B_{HYS}			-	20	-	Gauss
Magnetic Para. (Z-Axis)						
B_{OPS}	Magnetic Operating Point		-	30	50	Gauss
B_{OPN}			-50	-30	-	
B_{RPS}	Magnetic Release Point		5	20	-	Gauss
B_{RPN}			-	-20	-5	
B_{HYS}	Hysteresis Window		-	10	-	Gauss

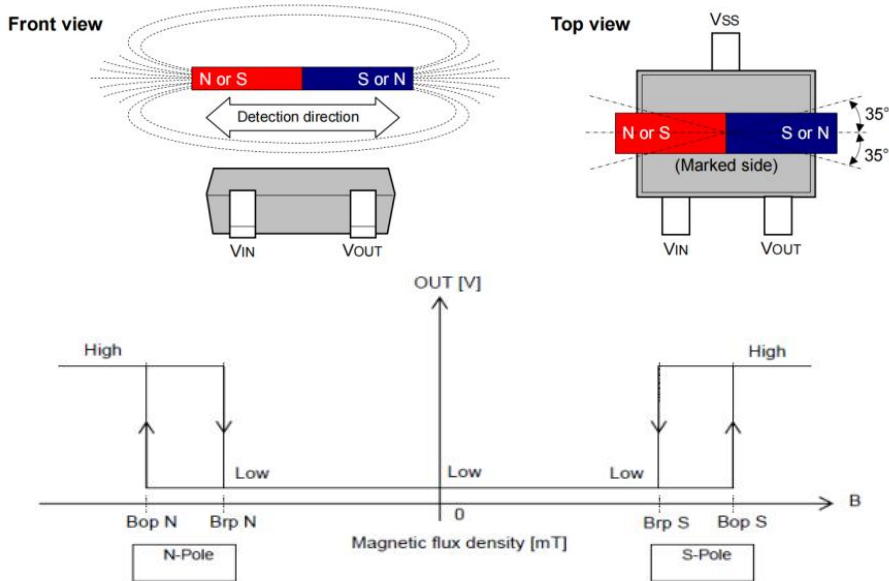

Fig 4A, X-Axis Magnetic Operation Characteristic of AS1153

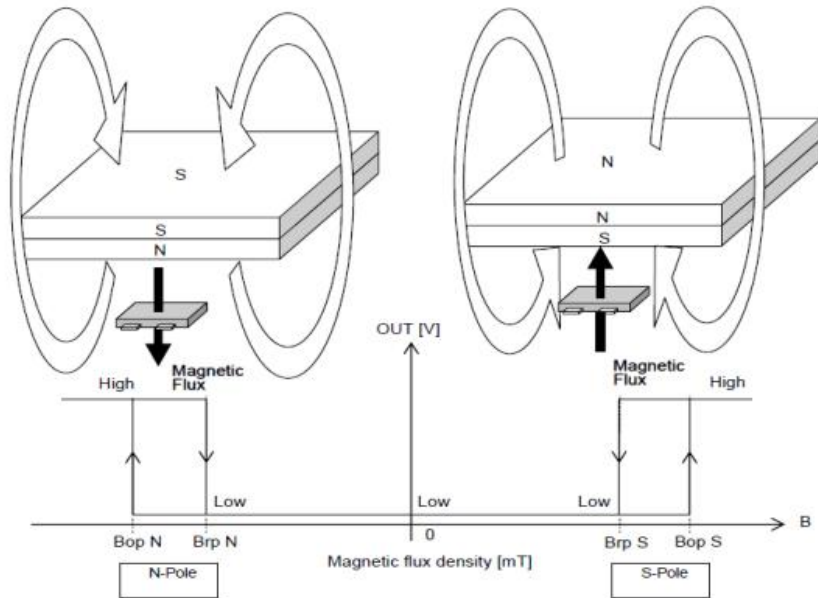
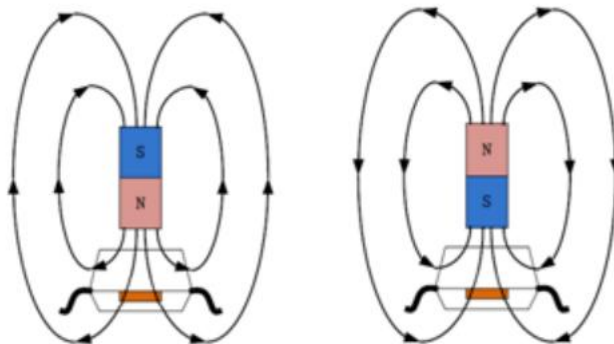

Fig 4B, Z-Axis Magnetic Operation Characteristic of AS1153

■ **Hall Sensor Location**

A positive magnetic field is defined as a south pole near the marked side of the package.



If the device is powered on with a magnetic field strength between BRP and BOP, then the device output is determinate High. For SOT23-3L package, if the field strength is greater than BOP, then the output is pushed high. If the field strength is less than BRP, the output is pulled low.

■ **Function Description**

Chopper-Stabilized Technique

The Hall element can be considered as a resistor array similar to a Wheatstone bridge. A large portion of the offset is a result of the mismatching of these resistors. These devices use a proprietary dynamic offset cancellation technique, with an internal high-frequency clock to reduce the residual offset voltage of the Hall element that is normally caused by device over-molding, temperature dependencies, and thermal stress. The chopper-stabilizing technique cancels the mismatching of the resistor circuit by changing the direction of the current flowing through the Hall plate using CMOS switches and Hall voltage measurement taps, while maintains the Hall voltage signal that is induced by the external magnetic flux. The signal is then captured by a sample-and-hold circuit and further processed using low-offset bipolar circuitry. This technique produces devices that have an extremely stable quiescent Hall output voltage, are immune to thermal stress, and have precise recoverability after temperature cycling. A relatively high sampling frequency is used for faster signal processing capability can be processed.

Operation

The output of this device switches low (turns on) when a magnetic field perpendicular to the Hall sensor exceeds the operate point B_{OPS} (or is less than B_{OPN}). After turn-on, the output is capable of sourcing up to 30mA and the output voltage is high $V_{OUT(ON)}$. When the magnetic field is reduced below the release point B_{RPS} (or increased above B_{RPN}), the device output switches low (turns off). The difference between the magnetic operates and release points are the hysteresis (B_{HYS}) of the device. This built-in hysteresis allows clean switching of the output even in the presence of external mechanical vibration and electrical noise.

■ **Applications:**

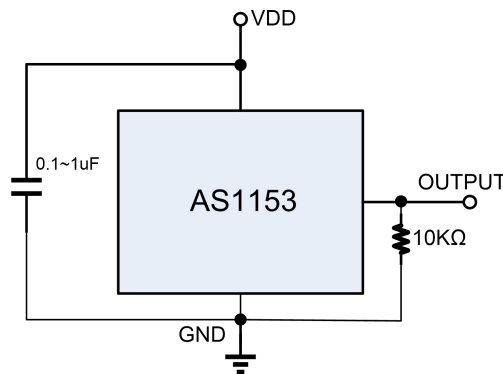

AS1153's pole-independent sensing technique allows for operation with either a north or south poles magnet orientation, enhancing the manufacturability of the device. The state-of-the-art technology provides the same output polarity for either pole face.

C1 serves two purposes: minimizing ripples on the input voltage and enhancing immunity from RF transmission noises within close proximity. Recommended values are between 100nF and 1uF. The larger the capacitance, the better the noise immunity is for the AS1153.

It is strongly recommended that an external bypass capacitor be connected (in close proximity to the Hall sensor) between the supply and ground of the device to reduce both external noise and noise generated by the chopper-stabilization technique. This is especially true due to the relatively high impedance of battery supplies. The simplest form of magnet that will operate these devices is a bar magnet with either pole near the branded surface of the device.

Thermal Considerations

The maximum IC junction temperature should be restricted to 125°C under normal operating conditions. This restriction limits the power dissipation of the AS1153. Calculate the maximum allowable dissipation, $P_{D(max)}$, and keep the actual dissipation less than or equal to $P_{D(max)}$. The maximum-power-dissipation limit is determined using following equation:

$$P_{D(MAX)} = \frac{125^{\circ}C - T_A}{R_{\theta JA}}$$

Where, T_A is the maximum ambient temperature for the application. $R_{\theta JA}$ is the thermal resistance junction-to-ambient given in Power Dissipation Table.

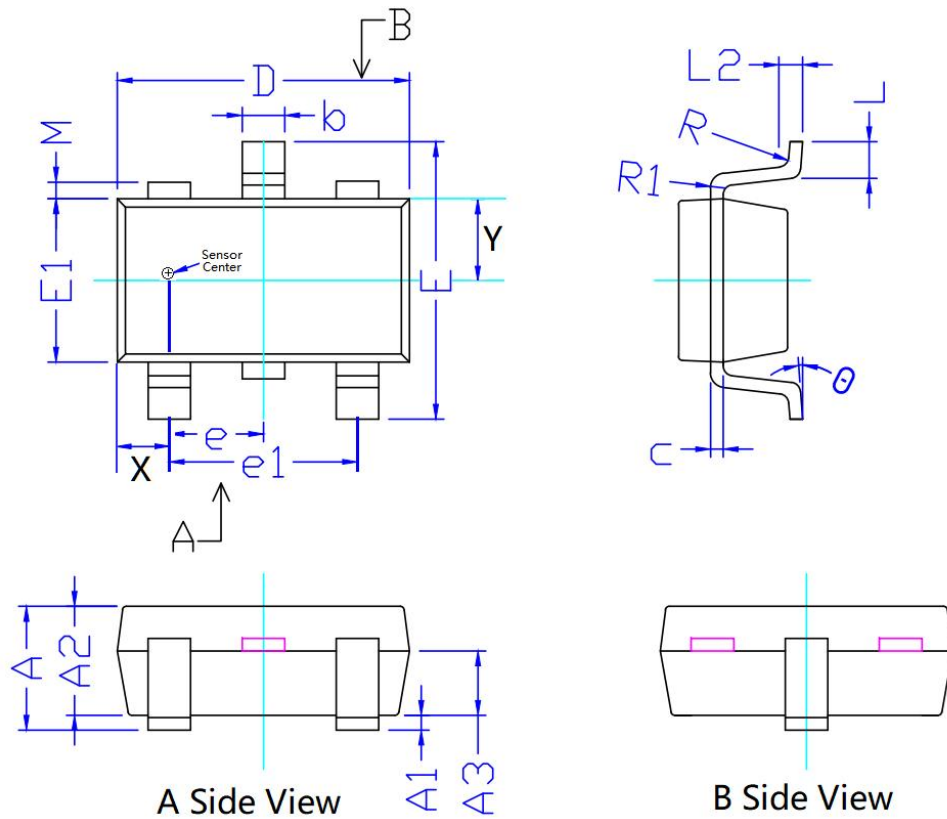
■ Package Information
SOT23-3L:

Symbol	Dimensions In Millimeters		Dimensions In Inches	
	Min.	Max.	Min.	Max.
A	1.050	1.350	0.041	0.053
A1	0.000	0.150	0.000	0.006
A2	1.000	1.200	0.039	0.047
A3	0.600	0.700	0.024	0.028
b	0.300	0.500	0.012	0.020
c	0.080	0.200	0.003	0.008
D	2.820	3.026	0.111	0.119
E1	1.500	1.726	0.059	0.068
E	2.600	3.000	0.102	0.118
e	0.950 (BSC)		0.037 (BSC)	
e1	1.900 (BSC)		0.075 (BSC)	
L	0.300	0.600	0.012	0.024
L2	0.250 (BSC)		0.010 (BSC)	
R	0.050	-	0.002	-
R1	0.050	0.200	0.002	0.008
θ	0°	8°	0°	8°
X	0.500 (BSC)		0.020 (BSC)	
Y	0.800 (BSC)		0.031 (BSC)	

■ Packing Information

SOT23-3L:

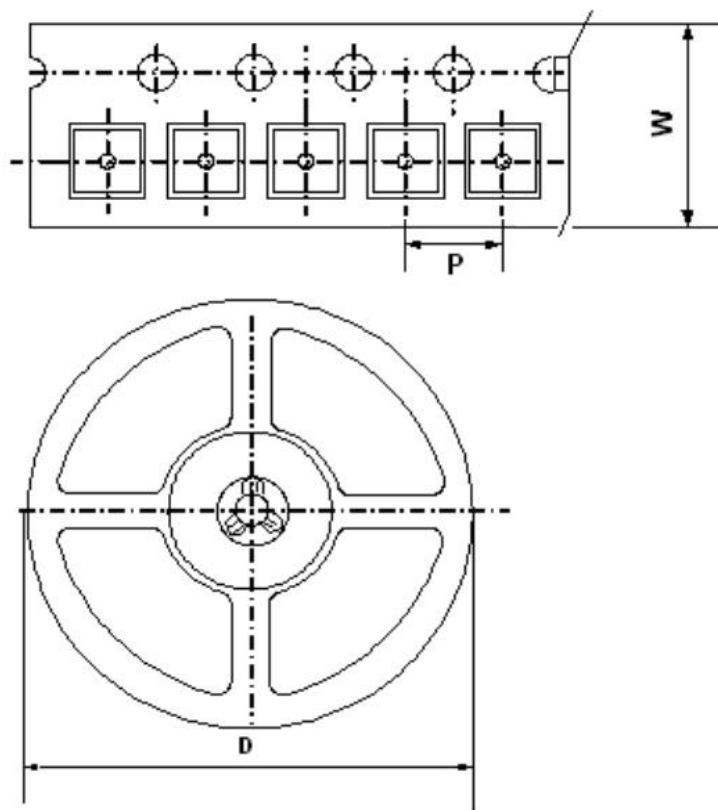

Package Type	Carrier Width(W)	Pitch(P)	Reel Size(D)	Packing Minimum
SOT23-3L	8.0±0.1 mm	4.0±0.1 mm	180±1 mm	3000pcs

Note: Carrier Tape Dimension, Reel Size and Packing Minimum